

Erfolg mit IBM Highend Servern: Kundenbeispiele

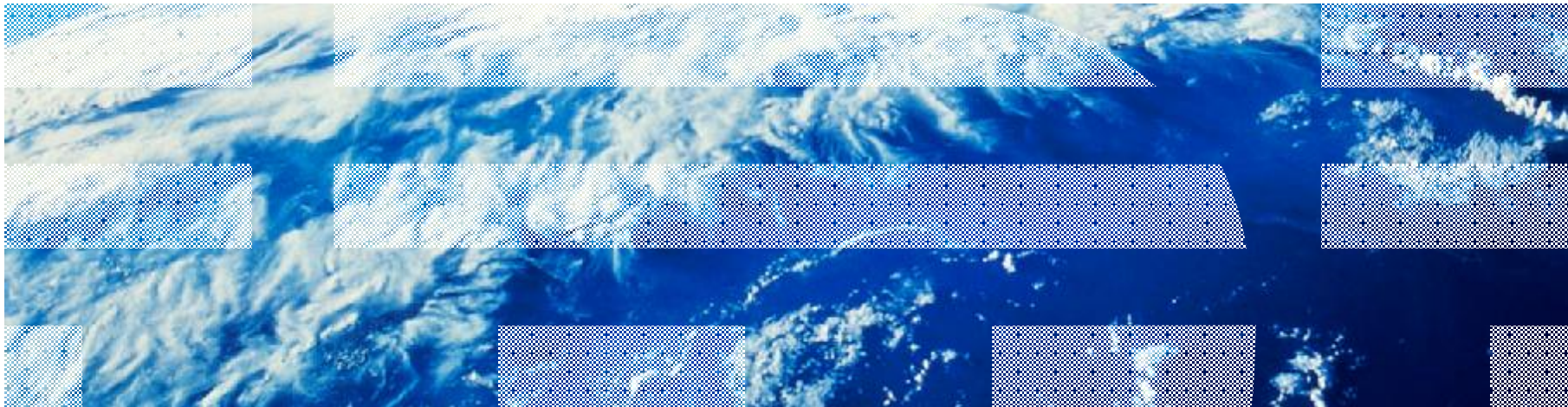

The expanding System z community

§ Continued growth on the System z platform in 2008

- Over 150 new ISV partners
- 1,000 new applications
- More than 500 new Linux applications added

§ ISV Partner loyalty

- Over 1,600 ISVs building applications for System z
- 3,000+ applications for Linux on System z

§ Academic Initiative delivering mainframe skills:

- More than 600 schools participating
- More than 50,000 students trained
- 30 courses and more to come
- Student MF Contests
- z Skills Help Desk
- Over 200 z IBM Mainframe ambassadors
- Assist Professors

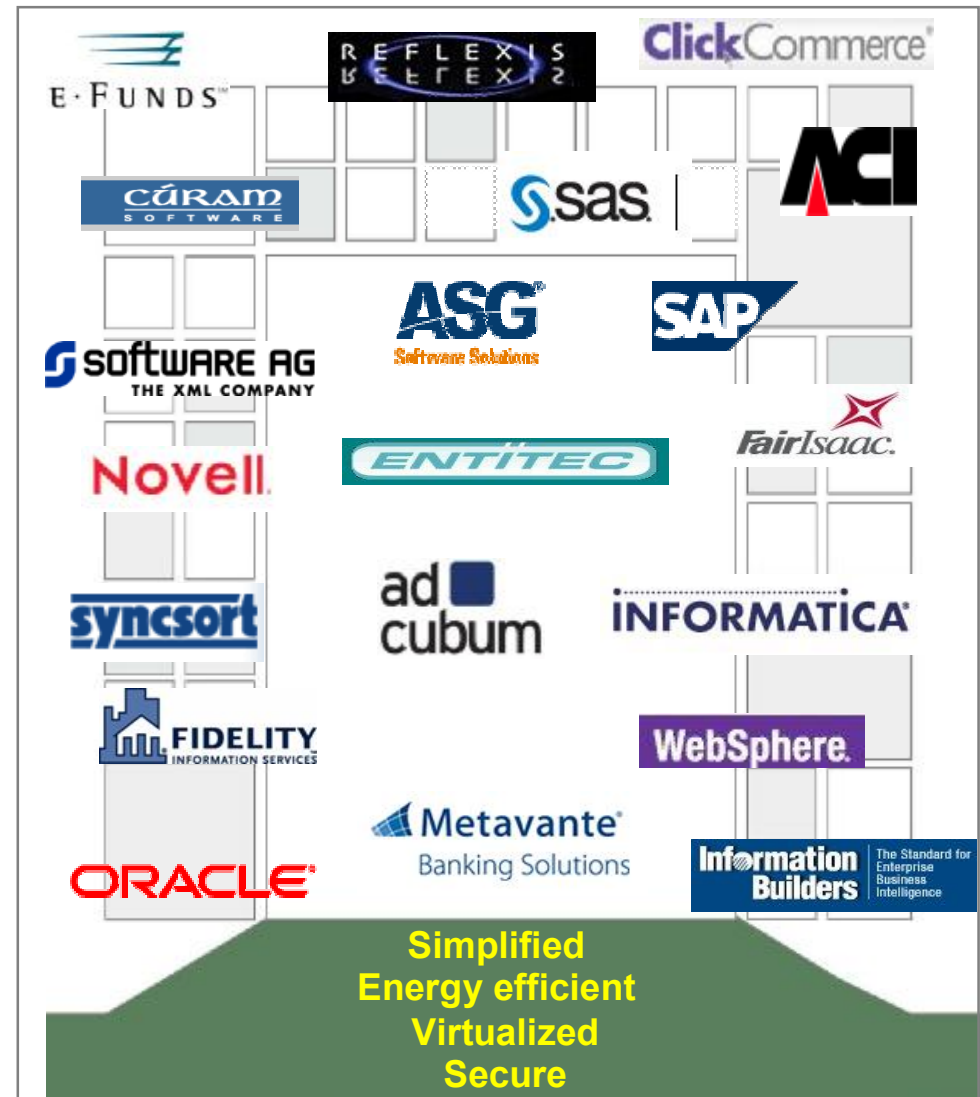

Clients are using the mainframe to address their key challenges today

- § 77% increase in Linux on System z MIPS in 2008 (+53% in Q1 2009)
- § 22 of 54 new System z clients installed Linux in 2008
- § Approximately 1,300 System z customers are now using Linux on z
- § System z has nearly doubled its share since Q4'00 from 17% to 32%¹ on a rolling 4 quarter basis

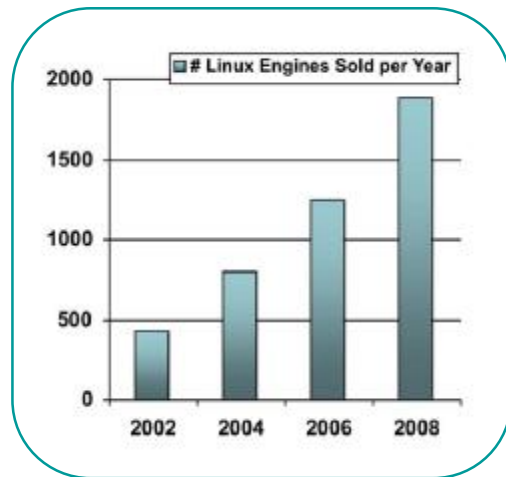

And the industry agrees

Growth and Innovation

*"...IBM has reinvented the mainframe. The **pursuit of new workloads** has been a critical aspect of the resurgence, while at the same time protecting and nurturing the installed base. The introduction of **specialty engines** has been a catalyst to the growth but represents only the first step toward a significant change in architecture during the next five years."*

Source: Gartner Data Center Conference, Dec. 2008 (Gartner The IBM Mainframe Platform Ongoing Challenges, New Opportunities)

"IBM's z10 is the computer industry's pinnacle systems platform. Blow-away performance (fast quad-core processors), increased capacity (1.5 times greater than its predecessor), and expanded memory (three times greater than its predecessor) makes this system the absolute best scale-up architecture — bar none — in the computing industry." Joe Clabby, Clabby Analytics, February 26, 2008

Cost Effective and Modern

Simplifying IT

*"For those IT organizations that have seen the light and are moving their emphasis from the never-ending challenge of trying to optimize their IT infrastructure to the more important **optimizing of the delivery of IT services, nothing beats the mainframe,**"* Mike Kahn, The Clipper Group, February 2008

***System z remains a growing product line** for IBM because, during the past decade, it has morphed historical strengths into new forms aligned with today's languages, operating environments, and computing standards. And, in fact, **System z strengths such as mitigating business risk** in many forms have once again shoved their way to the fore of many IT departments' priorities. This includes protecting against hardware and site failures, managing a company's security policies and credentials, acting as a focal point for integrating the myriad applications that make up a business process, and being able to adapt to sharp spikes in load.* Gordon Haff, Illuminata, January 2009

Manage Risk

Large bank consolidates from HP and Sun saving power costs and gaining disaster recovery protection

	FROM ...	TO ...
Current hardware infrastructure	HP Proliant; Sun Fire, pSeries	z10 EC
Footprints	18	2 (2 separate sites)
Cores	63	3 IFLs
Peak Utilization	3% to 15% SURF data	74%
DB	Oracle	Oracle
OS	HP-UX, Windows	Linux + z/VM
Energy and floor space savings		\$28,000 per year

Summary of Benefits:

- § Energy savings
- § Disaster recovery capability
- § Better utilization

Prices are in USD. Prices may vary in other countries.

Data is based on real client opportunity and on internal standardized costing tools and methodologies.

Client results will vary by types of workloads, technology level of consolidated servers, utilization factor, and other implementation requirements. Savings will vary by client.

Bank of New Zealand ...

Reduces Carbon Footprint with Red Hat on the Mainframe



Business need

Bank of New Zealand (BNZ) was close to reaching capacity in its datacenter and needed a new solution that could maximize space and resources while keeping costs down. With a heavy carbon-neutral focus as a core part of its corporate values, BNZ looked for ways to green its IT architecture and carve out costs.

Solution

In mid 2007, BNZ began overhauling its mission-critical front-end IT environment, including its Internet banking and bank teller functions, and its middleware layer providing connectivity through to its core back-end data. It migrated its systems to Red Hat Enterprise Linux 5 running under z/VM on the mainframe. Today, BNZ utilizes both IBM System z10 and z9 systems, exclusively running Red Hat Enterprise Linux 5, to power the bank's customer-facing banking systems, including Internet banking and teller platforms.

Benefits:

- § Recovered 30 percent of datacenter floor space
- § 33 percent reduction in heat output and a 39 percent reduction in carbon dioxide emissions for its front-end systems
- § Reduced power consumption by 38 percent
- § 20 percent return on investment (ROI) over the life of the platform
- § The new virtualized platform has also boosted the speed and simplicity of new deployments.

“Deploying IBM mainframes with Red Hat Enterprise Linux to address our carbon footprint and cost savings concerns was a very big deal, especially at the senior management level.”

“We have also managed to substantially reduce our front-end power consumption by nearly 40 percent, which means we are well and truly on our way to becoming carbon-neutral by our 2010 goal,”

Lyle Johnston, infrastructure architect at BNZ

ibm.com/press/nz/en/pressrelease/26621.wss

Running SAP on System z



“I can host my warehouse, my business applications, and my DB2® database all on the same machine. This gives me huge performance advantages”.

Mr. Andrea Coccia, CIO
Colacem S.p.A.

Colacem believes that deploying SAP on Linux on a mainframe makes excellent business sense.



“We continue to require just eight of our 84 employees to run the SAP landscape on IBM System z® [technology]. This is only possible with the ease of administration that comes with using a centralized server on Linux for System z and [IBM] DB2® for [IBM] z/OS® software.”

— Dieter Schiffer, gkd-el



“Migration of SAP application servers to zLinux produced immediate increase in performance, made it easier to manage and maintain our systems. Consolidation to a single platform has helped us manage our growing user base without increasing headcount . We have gone from 2,000 SAP users to 3,700, using the same IT resources as before.

“The entire project was implemented on time and on budget. By implementing the IBM Systems solution for SAP BI Accelerator, query performance has improved significantly. One query that used to take 30 minutes to process now runs successfully within two minutes.”

SAP Architecture and Infrastructure

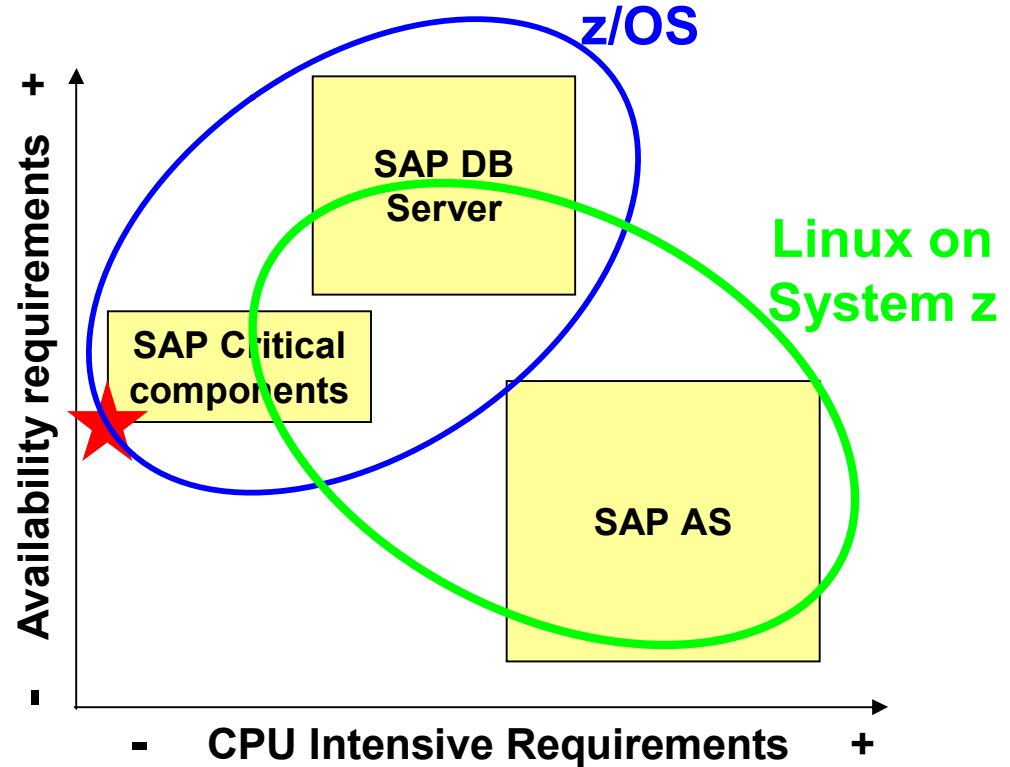
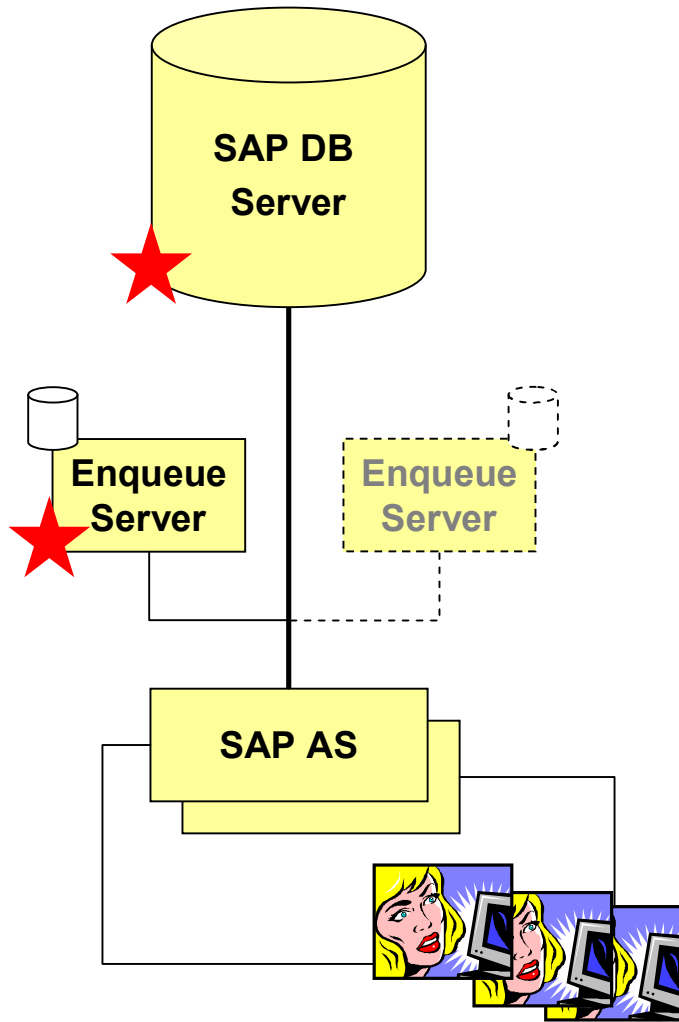

- § Production, test, development, and training environments
- § Continuous availability requirements
- § Disaster recovery

Systems for Car Parks and
Leisure Centres

Fare Collection Systems

Systems for Petrol Stations

Systems for Signal Technology

Systems for a mobile world

Scheidt & Bachmann

§ Introducing SAP and continuing current legacy workload on single server



Scheidt & Bachmann: Introducing SAP on System z

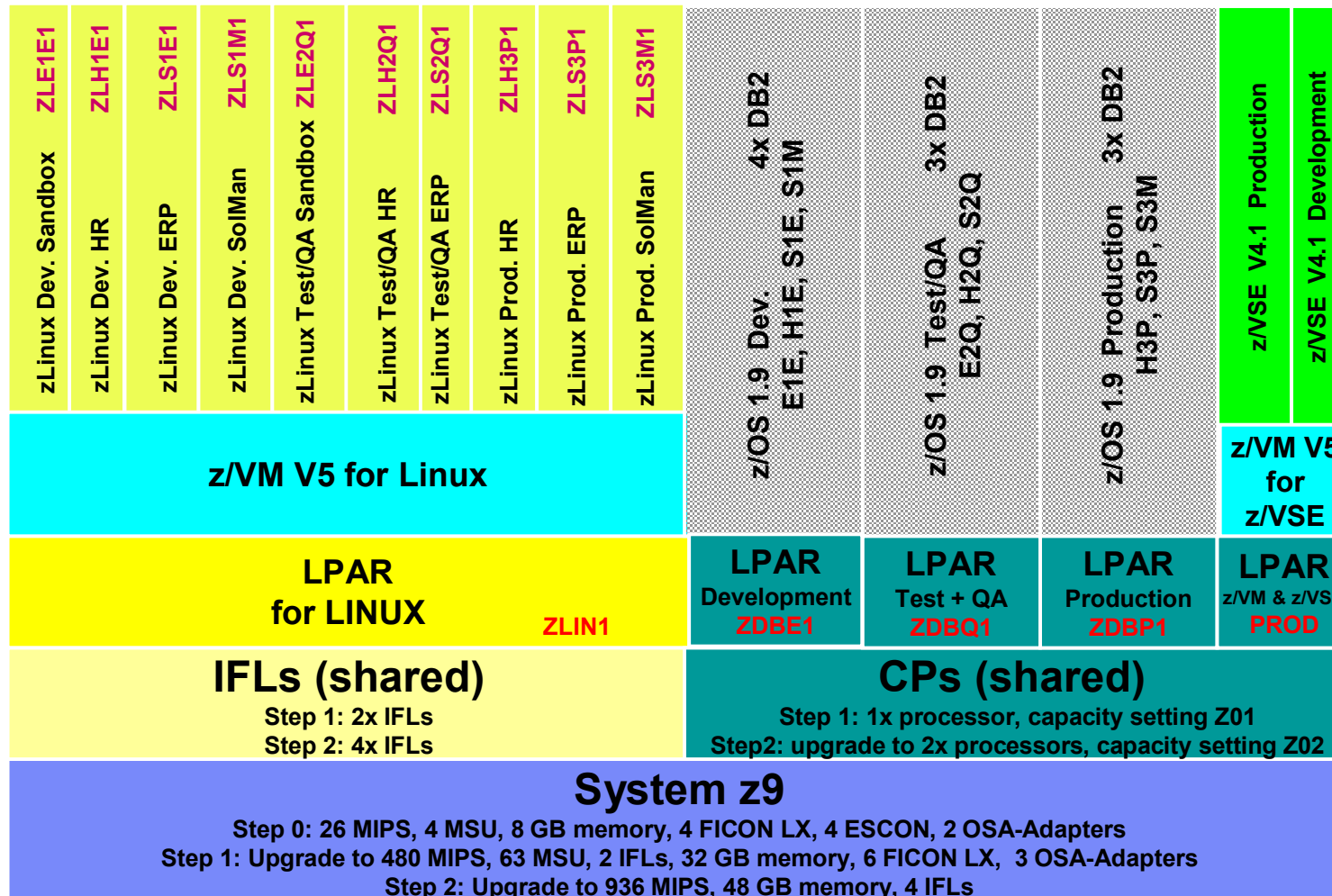

A new high-performance platform for Oracle and Linux

“Our customers are rapidly adopting server virtualization and grid computing as a way to save space, energy and other costs. Oracle sees a growing number who are incorporating Oracle software with Linux virtual servers on System z as part of that strategy,” says Robert Shimp, Oracle vice president, Global Technology Business Unit. “With this announcement the IBM System z10 becomes an even more attractive platform for deploying Oracle Database, Oracle Fusion Middleware and the Oracle E-Business Suite.”



Oracle on zLinux – a solution providing superior consolidation characteristics



NOMURA

“Nomura adopted solutions rebuilding the backend mission critical database servers by Linux, IBM mainframe, and Oracle Real Application Clusters...
...the system shows the performance to process 1,000 transactions per second now.”

Mr. Toru Kanazawa, Managing, Director, Group IT Strategy Department - *LinuxWorld Japan 2006*

Transzap moves to System z for three 9's uptime

Business need

Transzap, founded in 1999, needed a computing platform that would scale to support its operations without requiring additional monthly costs in extra hardware, software or human capital. For Transzap, IBM System z brings technology planning, and controlled power and energy allocation to its former "rack and stack" distributed server environment.

Solution

Prior to installing the mainframe, Transzap's systems ran a distributed architecture of Dell and Linux servers which made it challenging to manage. The multiple servers made technical configurations complex and laborious. Additionally, the company incurred linear technology costs for its growth. .

Transzap now utilizes the System z9 BC with a number of Linux specialty processors and z/VM for running virtual Oracle database servers connected to 18 TB's of IBM DS6800 Enterprise Storage and IBM TS3400 Tape Library subsystems. The combined IBM solution represents the heart of the Transzap system, as the company also uses other equipment.

Benefits:

- § Three 9's uptime, or less than 45 minutes per month of downtime (99.9%)
- § Transzap now has an affordable solution to support rapid incremental growth and a system that is reliable, centrally managed and highly secure



"Transzap operates Oildex, the energy industry's top ePayable system and digital data exchange.

We're a small company but our transaction data volumes are growing upwards of 100 percent, annually. We couldn't trust our business to any competitive product other than the IBM System z.

We didn't have any mainframe experience, and also had been a distributed, open systems shop, but there was this idea that possibly a System z that could run a series of virtual Linux machines could be a solution for us," says Peter Flanagan, CEO of Transzap.

ibm.com/de/pressroom/presseinfos/2008/10/21_2.html

Oracle HA with System z

Oracle RAC

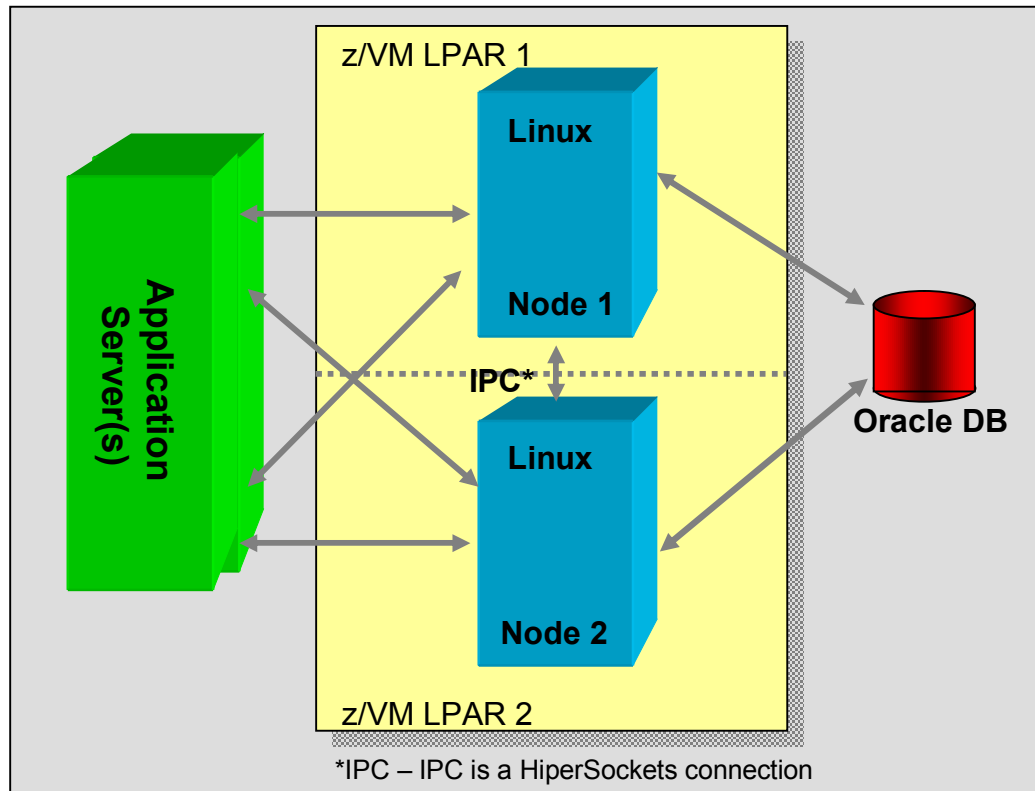

- § Guards against Linux failure, LPAR failure, z/VM failure, Oracle instance failure, LPAR maintenance
- § Can be: Active/active, active/passive
- § Not limited to two nodes

Server provided HA

Oracle →

- RAC
- Data Guard
- Flashback
- CRS
- Grid Control

Operating system HA

Linux →

- Linux Clustering

z/VM →

- Mature Hypervisor
- Hardware assist

Hardware provided HA

System z →

- Spare CPUs
- N+1 power supplies
- Chip sparring in memory
- Concurrent maintenance
- 50 years MTBF (system fail.)

Bank of Tokyo-Mitsubishi UFJ



Bank of Tokyo-Mitsubishi UFJ

Customer Profile:

- § Bank of Tokyo-Mitsubishi and UFJ Bank were merged in 2006 to form Bank of Tokyo-Mitsubishi UFJ, Japan's largest bank.

<i>Accounts</i>		<i>Branch Network</i>		<i>Financial Status (March 2007)</i>	
Retail	60M	Domestic	672	Asset	\$1.74 trillion
Corporate	400K	Overseas	113	Capital Stock	\$13 billion

Customer Issues & Requirements:

- § Branch servers (i.e. system infrastructure for tellers to input and query various transactions such as payment, transfer, bill of exchange, etc.) were based on Windows NT and reached the end of support
- § About 800 servers constantly causing troubles
- § Lower TCO by consolidating servers on a stable & reliable system
- § Core banking applications, developed and maintained by Fujitsu, needed easily to be ported to new platform
- § Needed Disaster Recovery solution

BTMU: IBM's Solution Overview



Bank of Tokyo-Mitsubishi UFJ

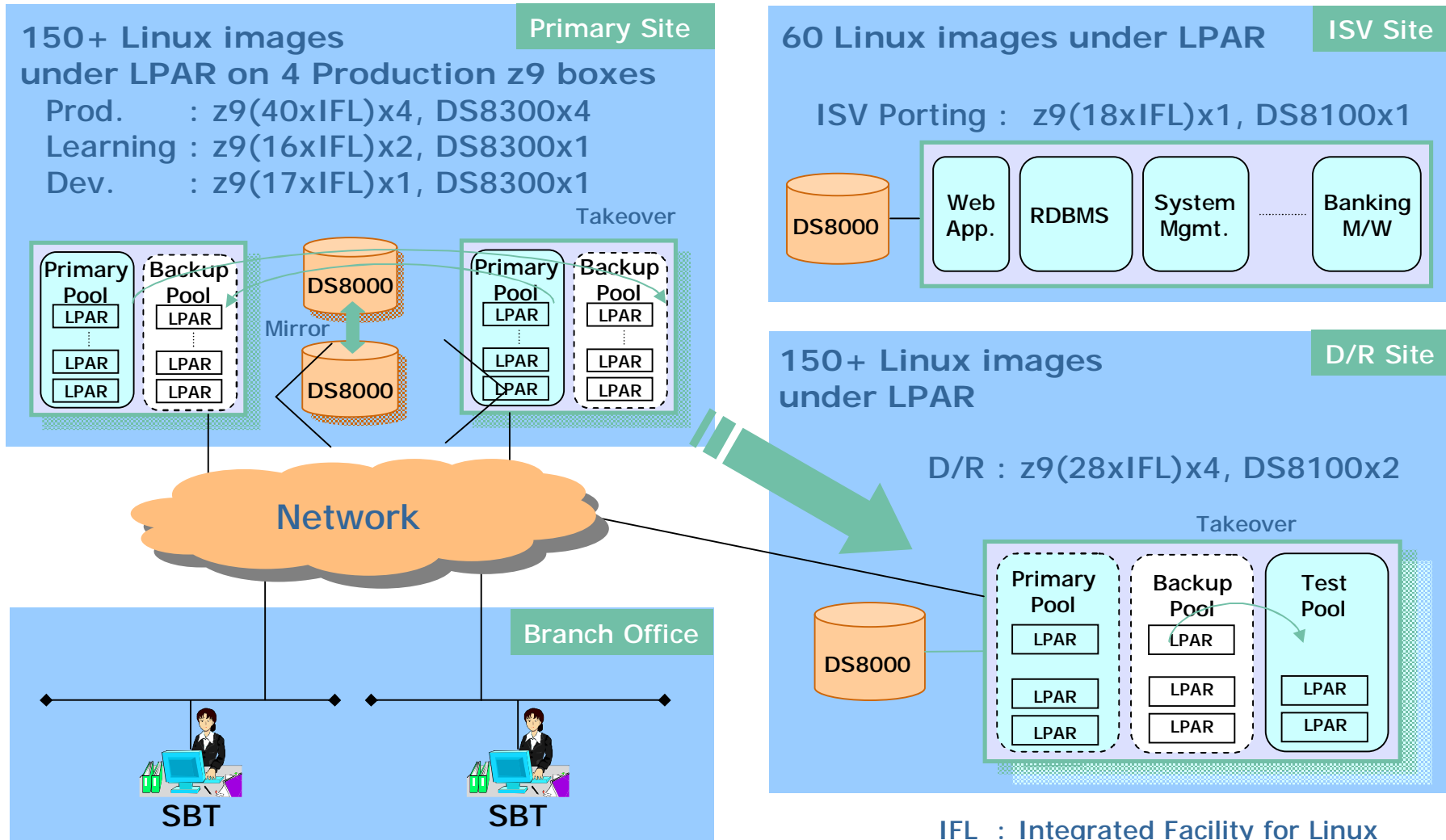

IFL : Integrated Facility for Linux
SBT : Super Banking Terminal

BTMU: IBM's Solution Summary



Bank of Tokyo-Mitsubishi UFJ

Category	# of z9	# of IFL	Memory (GB)	# of LPAR	# of DS8000	Disk (TB)
Production	4	160	1536	138	4	300
D/R	4	112	1280	180	2	60
Training	2	32	416	42	1	13
Development	1	17	128	15	1	4
Porting	1	18	128	60	1	6
Total	12	339	3488	435	9	383

Probably the largest Linux on System z installation in the world!

BTMU: The "Green Effect"



Bank of Tokyo-Mitsubishi UFJ

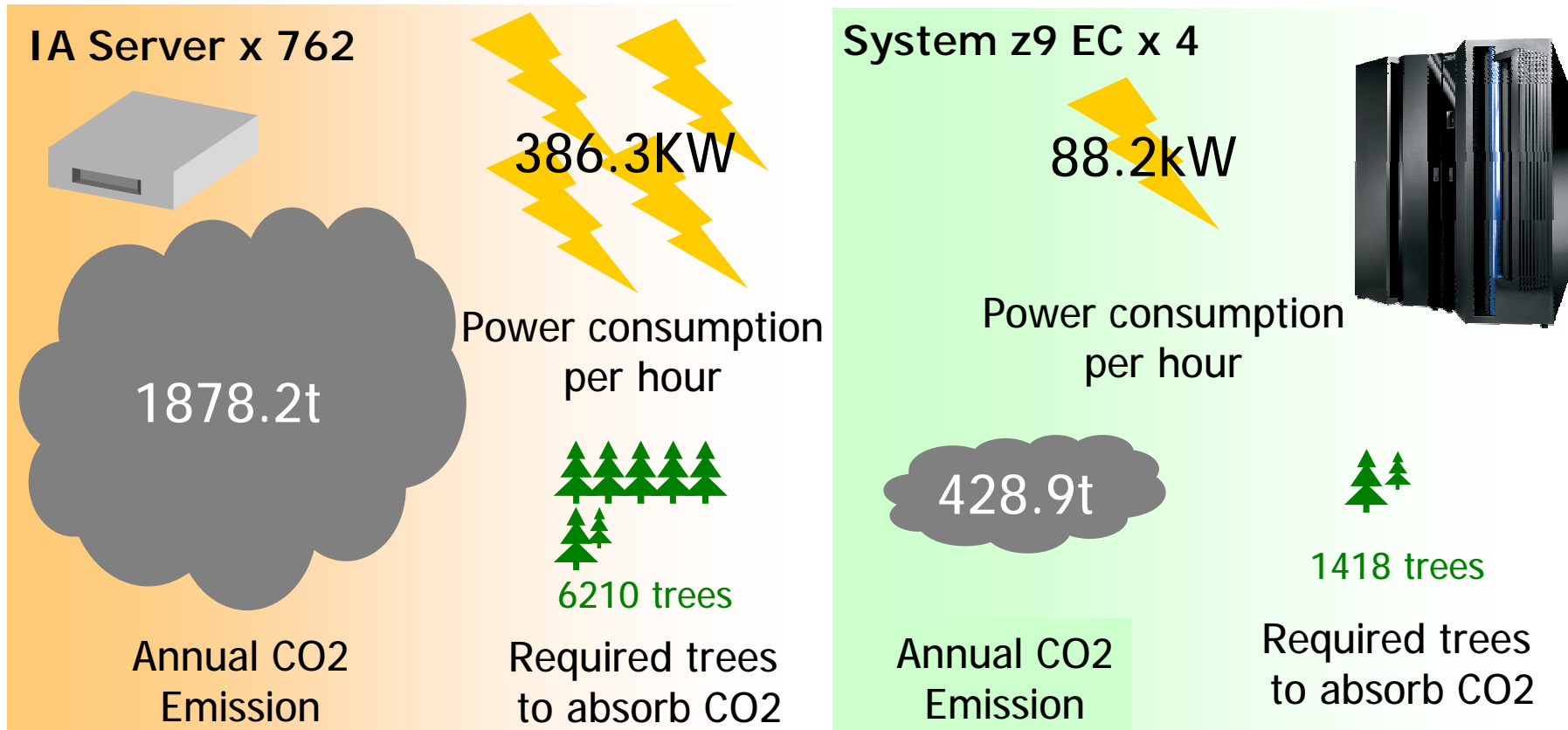

- § Zodiac study shows huge green effect through this consolidation.
- § More effect can be expected with the consolidation of UFJ servers.

System z: The journey continues...

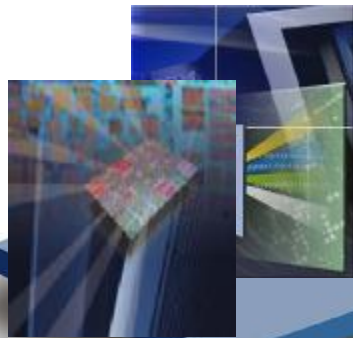

Specialty Engines (IFL, zAAP, zIIP)
Lowering the cost of deploying new workloads



IBM System z10 - The worlds most powerful enterprise computing platform
Performance
Capacity
Resilience
Responsiveness
Expanded offload on zIIP
LOW COST OF OWNERSHIP



Integrated or network attached Accelerators
Delivering new functionality
Increasing efficiencies
Enabling new solutions
Superior price/performance

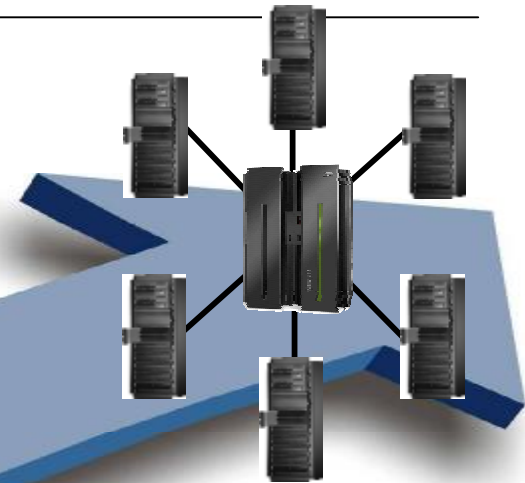

The next evolution of IBM Mainframe computers
Extend mainframe qualities to a heterogeneous Dynamic Infrastructure® to Support Business Critical Applications



Questions and Answers

**For more information, please
contact me at:
Siegfried.Langer@de.ibm.com**

Trademarks

The following are trademarks of the International Business Machines Corporation in the United States and/or other countries.

IBM*	FlashCopy	System p	WebSphere*
IBM logo*	Geographically Dispersed Parallel Sysplex	System Storage	z/OS*
Cognos*	GDPS*	System z*	z/VM*
DB2*	HiperSockets	System z9*	z/VSE
DB2 Connect	HyperSwap	System z10	zSeries*
Dynamic Infrastructure*	Informix*	System z10 Business Class	z9
Enterprise Storage Server*	MQSeries*	Tivoli	z10
ESCON*	OMEGAMON*	TotalStorage*	z10 BC
FICON*	Parallel Sysplex*	VSE/ESA	z10 EC

* Registered trademarks of IBM Corporation

The following are trademarks or registered trademarks of other companies.

INFINIBAND, InfiniBand Trade Association and the INFINIBAND design marks are trademarks and/or service marks of the INFINIBAND Trade Association.

Intel is a trademark of Intel Corporation in the United States, other countries, or both.

Java and all Java-related trademarks and logos are trademarks of Sun Microsystems, Inc., in the United States and other countries

Linux is a registered trademark of Linus Torvalds in the United States, other countries, or both.

UNIX is a registered trademark of The Open Group in the United States and other countries.

Microsoft, Windows and Windows NT are registered trademarks of Microsoft Corporation.

Red Hat, the Red Hat "Shadow Man" logo, and all Red Hat-based trademarks and logos are trademarks or registered trademarks of Red Hat, Inc., in the United States and other countries.

* All other products may be trademarks or registered trademarks of their respective companies.

Notes:

Performance is in Internal Throughput Rate (ITR) ratio based on measurements and projections using standard IBM benchmarks in a controlled environment. The actual throughput that any user will experience will vary depending upon considerations such as the amount of multiprogramming in the user's job stream, the I/O configuration, the storage configuration, and the workload processed. Therefore, no assurance can be given that an individual user will achieve throughput improvements equivalent to the performance ratios stated here.

IBM hardware products are manufactured from new parts, or new and serviceable used parts. Regardless, our warranty terms apply.

All customer examples cited or described in this presentation are presented as illustrations of the manner in which some customers have used IBM products and the results they may have achieved. Actual environmental costs and performance characteristics will vary depending on individual customer configurations and conditions.

This publication was produced in the United States. IBM may not offer the products, services or features discussed in this document in other countries, and the information may be subject to change without notice. Consult your local IBM business contact for information on the product or services available in your area.

All statements regarding IBM's future direction and intent are subject to change or withdrawal without notice, and represent goals and objectives only.

Information about non-IBM products is obtained from the manufacturers of those products or their published announcements. IBM has not tested those products and cannot confirm the performance, compatibility, or any other claims related to non-IBM products. Questions on the capabilities of non-IBM products should be addressed to the suppliers of those products.

Prices subject to change without notice. Contact your IBM representative or Business Partner for the most current pricing in your geography.